

NEMTEK
www.nemtek.com



D25 and D28 Electric Fence Energizer

Instruction Manual



Table of Contents

Introduction & disclaimer _____	3
Guarantee _____	4
Nemtek group outlets _____	5
Foreword _____	6
Warnings and Instructions _____	7
Energizer groups _____	8
Mounting & battery replacement _____	11
PC Board replacement _____	12
Connections and configuration _____	13
Fence wiring diagrams _____	14
Bi-polar fence wiring diagrams _____	15
4-zone installation _____	16
Network card and Nemtek Connect _____	17
Large network _____	18
Detailed service indicators & Fuses _____	19
Installation notes _____	20
Programmable options _____	21
Appendix _____	33
Programmable options summary _____	36
IEC Safety Information _____	37

Introduction & disclaimer

INTRODUCTION

The DRUID D25 and D28 are energizers which are suitable for use in a security energizer group they however can also function as stand-alone energizers.

If they are used in a security energizer group they are only allowed to be installed by an authorized installer, who is a person suitable trained and certified to safely configure, install and maintain a security energizer fence system with an energizer from Nemtek (Pty) Ltd

The DRUID is a battery (12V 7AH nominal) operated energizer suitable for connection to mains 240V AC 50-60Hz and model with 110V AC 50-60HZ is also available.

The batteries to be used are rechargeable lead-acid batteries. Non-rechargeable batteries must not be used. The lead-acid batteries require venting and it is imperative that the energizer be situated in a well-ventilated area.

A new fully charged battery will typically provide in excess of 24 hours backup. Backup time will vary with fence condition though.

Electric fencing can be lethal. Please avoid entanglement\entrapment hazards (See APPENDIX at the end of this manual) and warn the user to avoid head contact with the fence.

DISCLAIMER

NEMTEK Holdings (Pty) Ltd or any of its subsidiary companies does not guarantee that the operation of the product will be uninterrupted or totally error free.

Energizer specifications may be altered without prior notification.

The installer is referred to the definitions and general requirements in the Appendix.

The installer must take into consideration the applicable municipal laws concerning the installation of electric fences. General guidelines are available, or refer to the website: <http://www.nemtek.com>. International standards can be viewed at <http://www.iec.ch> and South African standards on <http://www.sabs.co.za>.

GUARANTEE

The Druid Electric Fence Energizer, manufactured by NEMTEK, is guaranteed for a period of two years from date of sale against defects due to faulty workmanship or materials.

NEMTEK will, at its discretion, either repair or replace a product that proves to be defective.

NEMTEK guarantees that the product, when properly installed and used in line with the specification as determined by NEMTEK from time to time, will execute its function of generating a suitable potential. NEMTEK does not guarantee that the operation of the product will be uninterrupted and totally error free. Faulty units must be returned to one of the NEMTEK Group outlets. The buyer shall pay all shipping and other charges for the return of the product to NEMTEK or NEMTEK Security Warehouse.

LIMITATION OF GUARANTEE

The guarantee does not apply to defects resulting from acts of God, modifications made by the buyer or any third party, misuse, neglect, abuse, accident and mishandling.

EXCLUSIVE REMEDIES

The remedies provided herein are NEMTEK's sole liability and the buyer's sole and exclusive remedies for breach of guarantee. NEMTEK shall not be liable for any special, incidental, consequential, direct or indirect damages, whether based on contract, tort, or any other legal theory. The foregoing guarantee is in lieu of any and all other guarantees, whether expressed, implied, or statutory, including but not limited to warranties of merchantability and suitability for a particular purpose.

NEMTEK Group outlets

HEAD OFFICE

Tel: +27 (0)11 462 8283

Fax: +27 (0)11 462 7132

Stand 206, Boundary Park

Cnr Malibongwe drive and Epsom Ave,
Northriding, Randburg, South Africa

EXPORTS

Tel: +27 (0)11 462 8283

Fax: +27 (0)11 462 7132

exports@nemtek.com

EDENVALE

Tel: +27 (0)11 453 1970

Fax: +27 (0)11 453 1858

Unit 4, Meadowdale Park

Cnr. Dick Kemp & Herman Roads
Meadowdale, Edenvale, South Africa

CAPE TOWN

Tel: +27 (0)21 386-3742

Fax: +27 (0)21 386-5573

27B Concord Crescent, Airport City

Cape Town, South Africa

NELSPRUIT

Tel: +27 (0)13 752-2187

Fax: +27 (0)13 752-2188

Waterval Ave, Riverside Industrial

Nelspruit, South Africa

KWAZULU-NATAL

Tel: +27 (0)31 701-2125

Fax: +27 (0)31 701-2125

19 Henwood Road

Pinetown, South Africa

BLOEMFONTEIN

Tel: +27 (0)51 004-0490

Unit 12, Plot 42, Gemsbokstreet

Quaggafontein, Freestate, South Africa

AUSTRALIA

Tel: (08) 9303 9855

Email: nemtek@bigpond.net.au

Unit 5, 19 Innovation Circuit,

Wangara, 6065, Perth, WA, Australia

Website: www.nemtek.com

E-mail: nemtek@nemtek.com

Manufactured in South Africa

Foreword

The DRUID LCD 2x energizer should ideally be operated by means of a remote keypad to obtain access to the many energizer features and receive the greatest protection. It can however be operated by means of a Nemtek tab or external switch.

The energizer includes many user and installer settings. These will be retained in the event of total power loss. i.e. the battery is exhausted during a prolonged mains failure.

The energizer can be configured as a master only 2 zone installation, or as a master and slave networked 4 zone installation. Only a master energizer can communicate with keypads and other devices present on the keypad bus.

A set of jumpers positioned above each of the three energizer relays, allow the relay contacts to be configured as either wet (providing 12V nominal power) or dry (potential free) contacts.

The energizer display will light with a blue (OFF), green (all is OK), yellow (alarm in history or other medium priority event) or red (active alarm condition exists) background to announce the energizer's state at a glance and from a distance.

The DRUID LCD energizer incorporates an advanced and patented fence voltage regulation, arc detection and avoidance system. What this means is, the fence energy is maintained at a higher level than would normally be possible using a conventional energizer on the same fence, when factors such as poor or damaged insulators, wet insulators after a rain storm, or salt build up on insulators (at the coast) prevent the fence from supporting a high voltage. A conventional energizer will push all available energy through any arcing that may occur across the insulator, thus reducing the fence's effectiveness. The DRUID LCD energizer however will detect the arcing and then attempt to operate the fence at a voltage just below that at which arcing occurs, thus maintaining higher energy levels on the fence and improving the effectiveness of the fence. Nemtek is the inventor and patent holder of this innovative technology.

Nemtek Connect

Nemtek Druid LCD 2x energizers can be upgraded for remote connectivity through a smartphone application or internet browser via **Nemtek Connect**. Contact Nemtek for more information on the hardware and software upgrades required.

Warnings and Instructions

- The instructions in this manual must be fully complied with in every respect
- A Security energizer group must be used at any point where two electric security fences can be contacted by a person at the same time
- Give special attention to the correct type selection and connections of security energizers used in a security energizer group
- A security energizer fence system should be checked for safety by an authorized installer prior to operation. An authorized installer is a person suitable trained and certified by Nemtek (Pty) Ltd for installing security energizers groups and fence systems.
- **DANGER: Failure to comply with the instructions could lead to a fatal electric shock.**
- Only type R security energizers or type S security energizers can be used in security energizer groups
- A type S security energizer shall not be used in a type R security energizer group
- A type R security energizer can be used in a type S security energizer group
- For a Nemtek type R security energizer group only D25 energizers can be used
- For a Nemtek type S security energizer group only D28 and D25 energizers can be used.
- No other makes, models or types than Nemtek D25 and D28 can be used in a Nemtek security energizer group or Nemtek security energizer fence system
- The energizers permitted configuration and connection are as shown under the wiring diagram in this manual
- The security energizer impulse timing signal for synchronisation of the energizer can only be supplied from:
 - a) The sync output of a D25 or D28 independently timed security energizer
 - b) Nemtek's GPS unit, Druid synchronisation module (EE-LCD2x/GPSync)
 - c) Nemtek's Druid RS 485 card (EE-D/485/1)
- An authorised installer is a person suitable trained and certified to be able to safely configure, install and maintain a security energizer fence system on the basis of professional training, knowledge, experience and familiarity of the relevant equipment.
- A security energizer fence system must be configured and installed and shall be serviced and maintained by, or under the responsibility of an authorized installer
- After installation and after servicing, a label shall be attached to each energizer in a security energizer group that provides the authorized installer's name, contact details and installation or service date.

Energizer groups

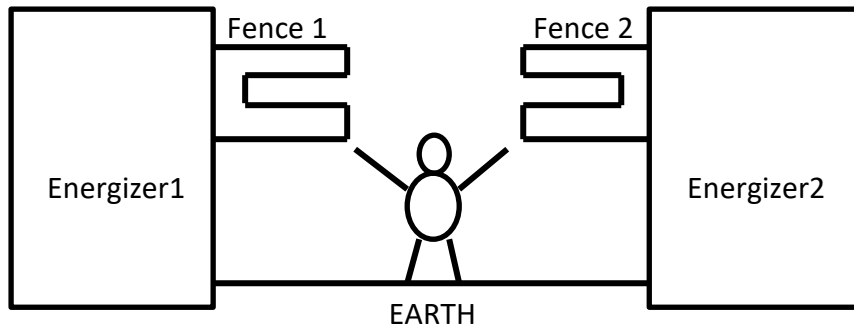

TOUCHING TWO FENCES AT THE SAME TIME

If two fences are touched by a person and the fences are supplied by independently timed energizers it is possible that the person will receive a lethal shock.

Each energizer on its own can be compliant to the regulations but combining the two energizers by touching their fences at the same time could make the impulses received not compliant to the regulations. The energy in the impulse could be too large or two impulses are not spaced apart enough in time. This could be extremely dangerous and could lead to a lethal shock.

R AND S TYPE SECURITY ENERGIZERS

Time synchronised energizers are required to overcome the problem of the impulses being too far apart when at the same time touching two fences supplied from independent timed energizers. The timing of the periodic voltage impulses of these energizers is set by an external impulse timing signal so that the combined pulses from the two energizers will be within the allowed limit.

There are two types of dependently typed security energizers the R and S type energizer. The symbols which are labelled on the energizer are shown below.

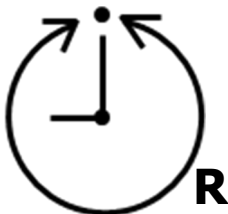

Time synchronised type R security energizer

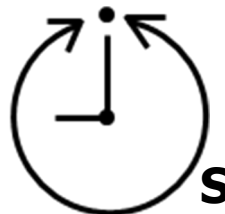

Time synchronised type S security energizer

Energizer groups

ENERGIZER GROUPS AND SECURITY FENCE SYSTEMS

The introduction of type R and type S energizers in security energizers groups makes it possible to contact two fence circuits at the same time without receiving a lethal shock.

To achieve this, the shock received should stay under any circumstance within the existing legal limit.

The type R energizer group is energy limited to 5 Joule which means that the two energizers combined should never give more than 5 Joule output. Not only has the total energy be correct, the impulse duration has to be under 10msec and there should be no more than one pulse per second. To achieve this the output pulses of the energizers, have to be synchronised. In a type R energizer group only type R energizers can be used. Only D25 can be used in a Nemtek type R energizer group no other types, models or makes are allowed

The type S energizer group is current limited and the combination of the two pulses, one from each energizer, should be under the curve for current limited energizers and not more than one pulse per second is allowed. Again, to achieve this synchronisation of the output pulses will be required. In a type S energizer group at least one S type energizer is used. In a Nemtek type S energizer group only D28 and D25 can be used no other types, models or makes are allowed.

In a security fence system, there can be more than one security energizer group and if a fence of one group is next to the fence of another group and it is possible to touch both fences at the same time it will be required to use the same synchronisation for the energizers in all the groups to ensure that combination of output pulses on adjacent fence stay in the legal limits. R and S energizer groups are not allowed to be adjacent to each other if two fences one of each group can be touched at the same time.

Energizer groups

SYNCHRONISATION EXAMPLES

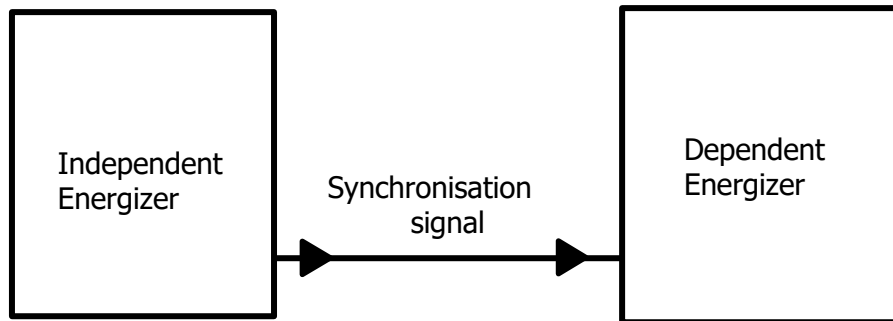

The independent energizer is used as the source for its own timing as well as the source for the dependent energizer.

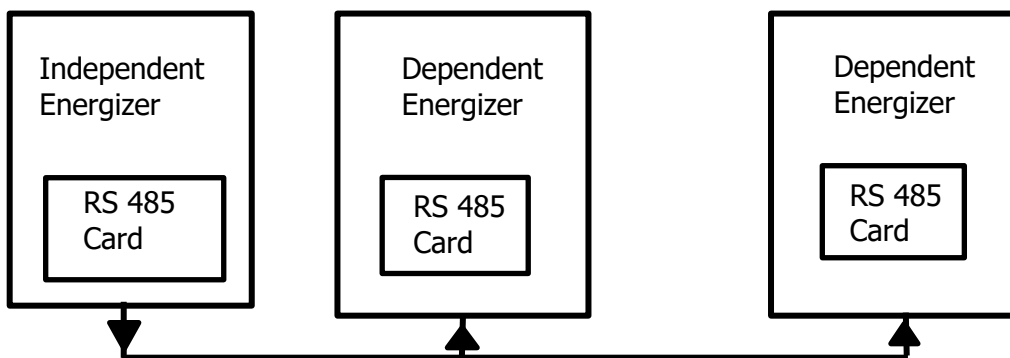

An independent energizer synchronizes two dependent energizers via RS 485

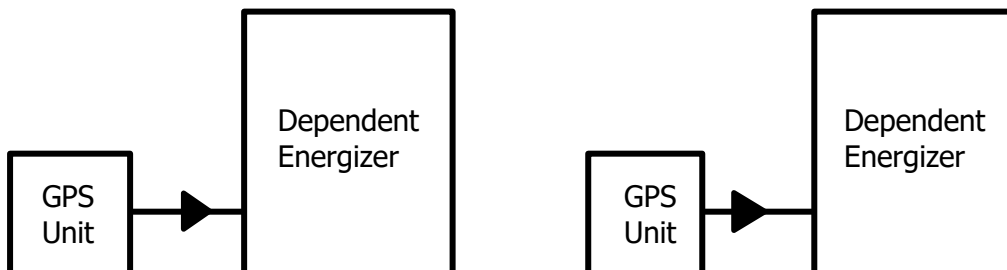

The GPS signal synchronizes the dependent energizers

Mounting & battery replacement

STEP 1: Disconnect mains. Open the lid after removing the two cap screws. Unplug the battery terminals if connected.

STEP 2: Remove screws and battery bracket

STEP 3: Remove battery

*Dispose of old battery according to legal requirements. Do not replace with a non-rechargeable battery!

STEP 4: Use a drilling template and drill 4 x 8mm holes in the wall for mounting the unit. Four nail-in anchors are supplied with the unit. Insert the plastic sleeve of the nail in anchor into the wall then hammer the screw in with a screwdriver and hammer. Leave a gap slightly more than the thickness of the casing between screw heads and wall. Position the casing so that the screws go through the slots provided then drop it into position. Tighten the top 2 screws to secure the casing. The bottom two screws will slot into the casing for stability, they don't need to be tightened.

STEP 5: Insert battery with the negative terminal to the top.

STEP 6: Place the battery bracket back (with plastic offsets at the top) and fasten the screws into place.

STEP 7: Connect battery wires. Close the lid by hooking the top of the lid in first and then fasten the bottom down with the two cap screws. Apply mains power to the unit.

Note: Energizer to be mounted vertically against a flat surface, in a well-ventilated area.

Avoid prolonged exposure to direct sunlight.

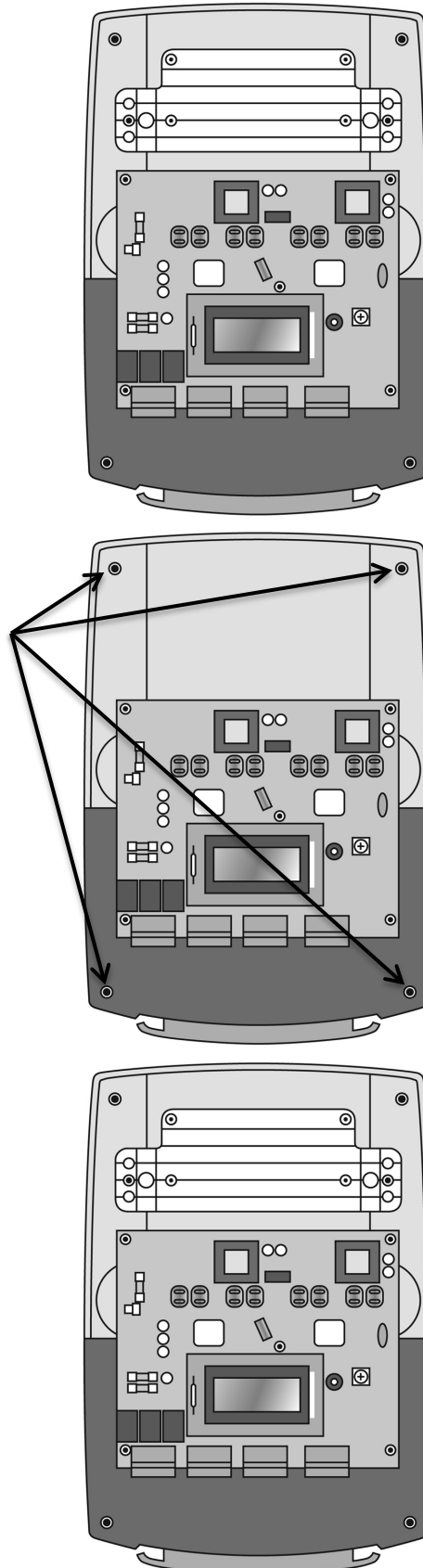

PC Board replacement

STEP 1: Disconnect mains power and the battery terminals if connected.

STEP 2: Remove all five connectors, C1 – C5.

STEP 3: Remove the five screws, S1 – S5.

STEP 4: To remove the PC Board, gently pull the PC Board away from the mounting plate, unplugging it from the connectors beneath it. There are four spade connectors beneath the PC Board in the middle of the board and two box connectors beneath and near the bottom of the board.

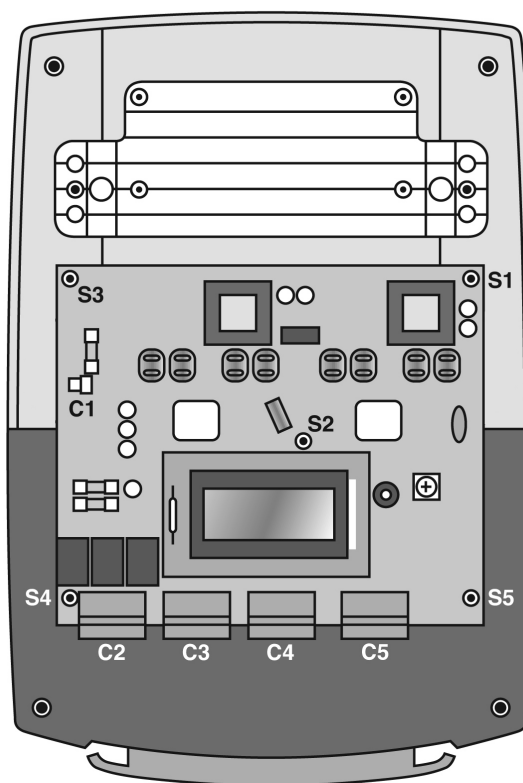

STEP 5: To replace the PC Board, first align the box connector near the bottom of the PC Board and then align the four spade connectors at the top of the PC Board using the guide tabs, and gently press the PCB down into place.

STEP 6: Re-insert and tighten the five screws.

STEP 7: Reconnect the five connectors to the PC Board.

STEP 8: Reconnect the battery terminals and apply mains power.

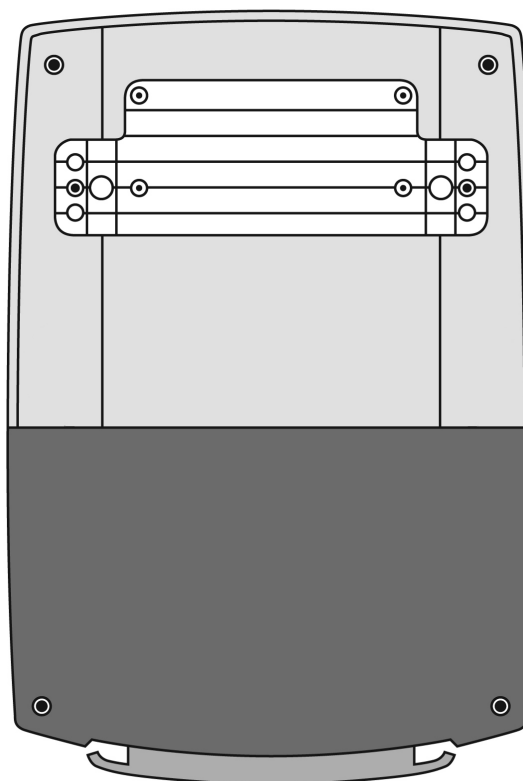

Connections

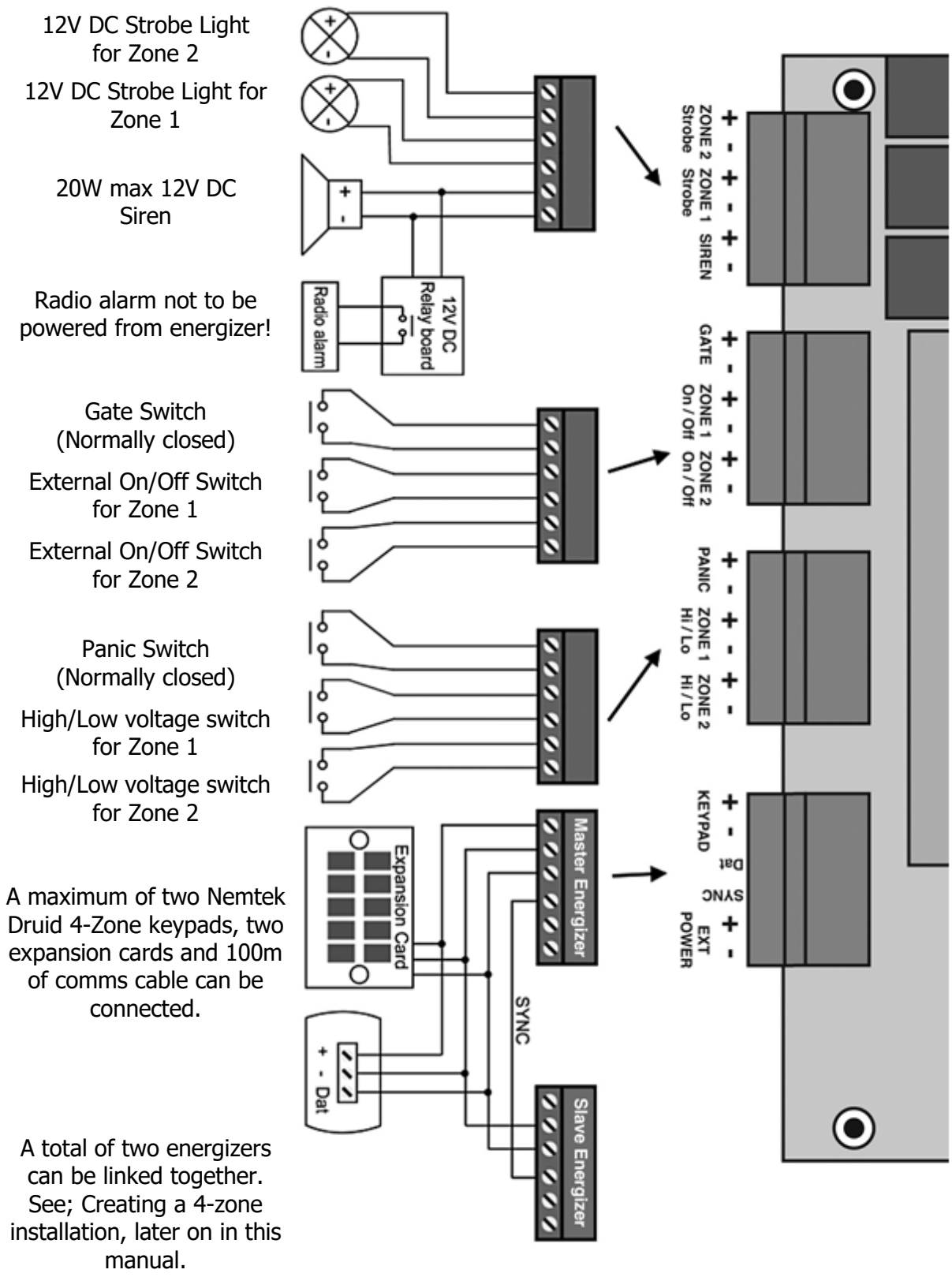

A maximum of two Nemtek Druid 4-Zone keypads, two expansion cards and 100m of comms cable can be connected.

A total of two energizers can be linked together. See; Creating a 4-zone installation, later on in this manual.

Fence wiring diagrams

The installation and erection of an electric fence in, South Africa, is to be done according to the latest addition of SANS 10222-3. In other countries, according to relevant specifications.

Live wire connection

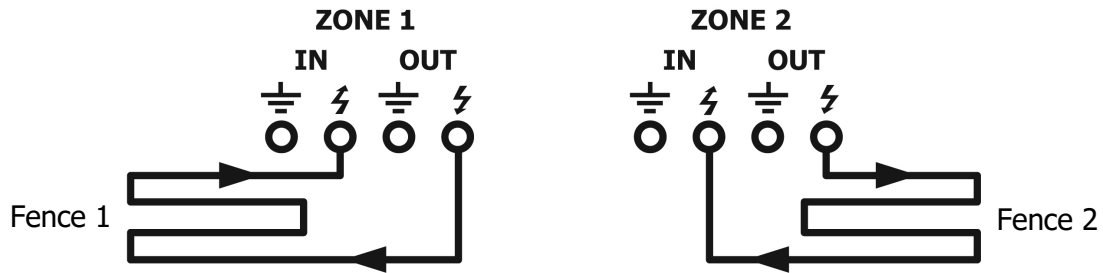

Earth wire connection with earth loop monitoring (preferred)

The fence earth wire is to be connected to the main earth spike and not directly to the energizer

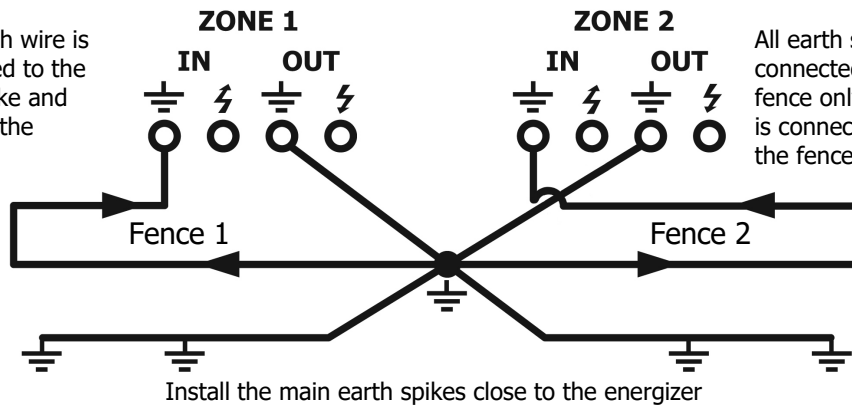

All earth spikes are connected to one wire of the fence only, and this one wire is connected to the rest of the fence at the main.

Earth wire connection with no earth loop monitoring

The fence earth wire is to be connected to the main earth spike and not directly to the energizer

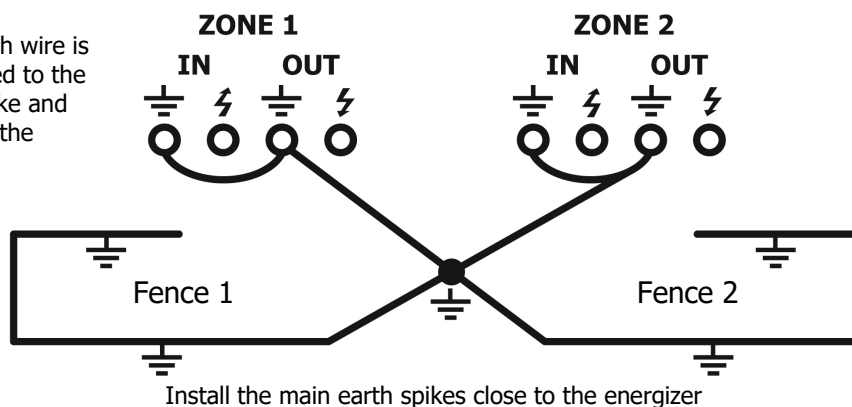

Bi-polar fence wiring diagrams

Live wire connection with double the voltage between adjacent strands

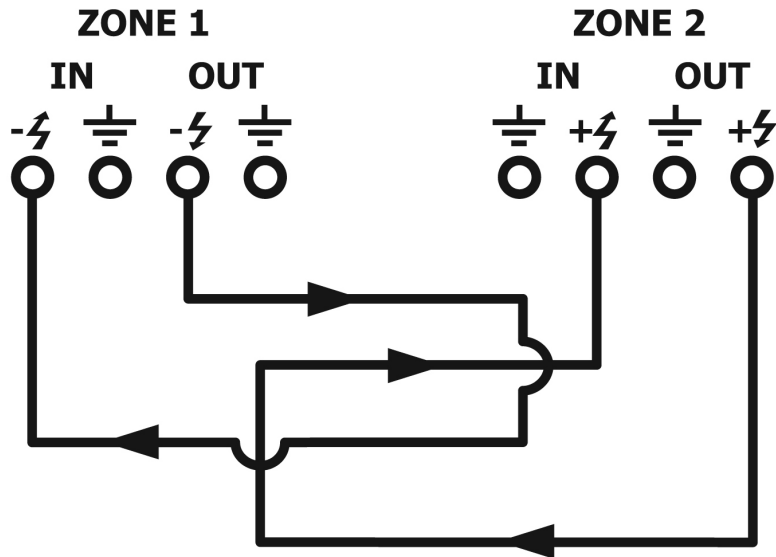

Earth wire connection with no earth loop monitoring

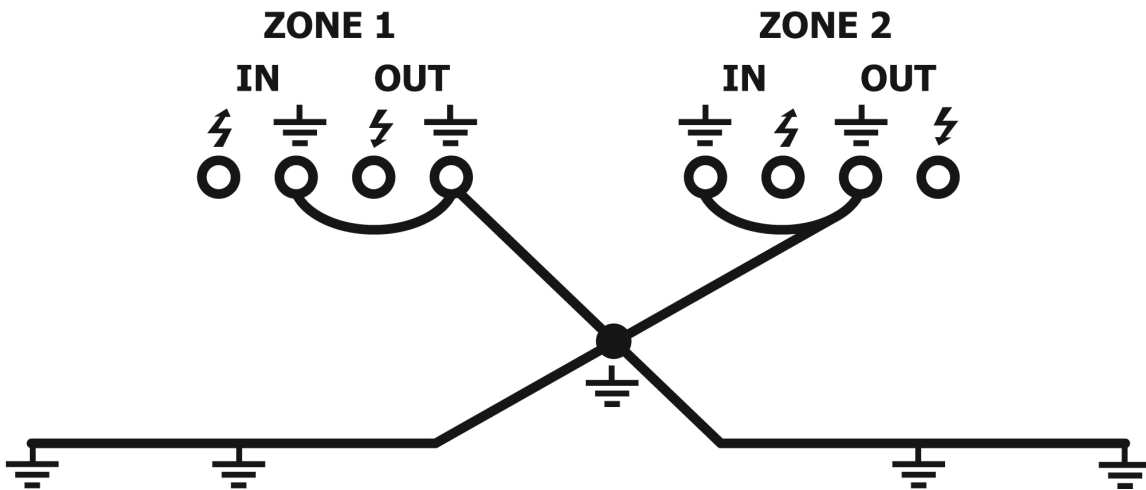

4-zone installation

CREATING A 4-ZONE INSTALLATION

Using two DRUID 2x energizers, a four-zone installation can be created. Implementing four zones, a property owner can identify the location of an attempted intrusion to a greater degree of accuracy. For example, the front, back, left or right side of the property can each be a unique zone.

To create a four-zone system, two DRUID 2x energizers need to be linked via the keypad bus. Three wires in total need to be wired correctly between the two energizers. The system ground (KEYPAD-) wire, the data wire (DATA), and the synchronization wire (SYNC).

One energizer must be configured as a master, and the other energizer configured as a slave. An energizer is configured by means of a Master/Slave jumper on the energizer main PCB, just below the LCD display. A master energizer will have the jumper absent, and a slave energizer must have the jumper inserted.

Master will show as zones 1 & 2 on the keypad.
Slave will show as zones 3 & 4 on the keypad.

Lastly, the master needs to be informed whether a slave energizer is connected creating a four-zone system or if it is a master only two-zone system. This is so that a communication failure (service alarm) can be generated should the slave energizer not respond to the master's request for information, and so that the keypad can be dealt with correctly as either a two or four zone installation.

The **SLAVE ENERGIZER PRESENT** setting is set by first entering installer mode, and then entering installer code **5001*#**. Further details of this code can be found in this manual under the **PROGRAMMABLE OPTIONS** section.

Note: Please read the section, **KEYPAD ZONE FOCUS**, in the Druid LCD User Manual Rev1.2 or later. This section explains how to direct keypad input to a specific zone, or to all zones simultaneously. Installer **PROGRAMMABLE OPTIONS** which are zone focus specific will have the following text appear below the programmable option later in this manual.

*Can be directed to a specific zone, using **KEYPAD ZONE FOCUS**.

Network cards and Nemtek Connect

The Druid LCD 2x energiser has a data port to which communications cards such as a network card or a Nemtek Connect card can be connected. These cards enable networking or remote access and control of the energiser.

Visit the Nemtek website, www.nemtek.co.za, for the latest details on the smartphone app and networking options available to you.

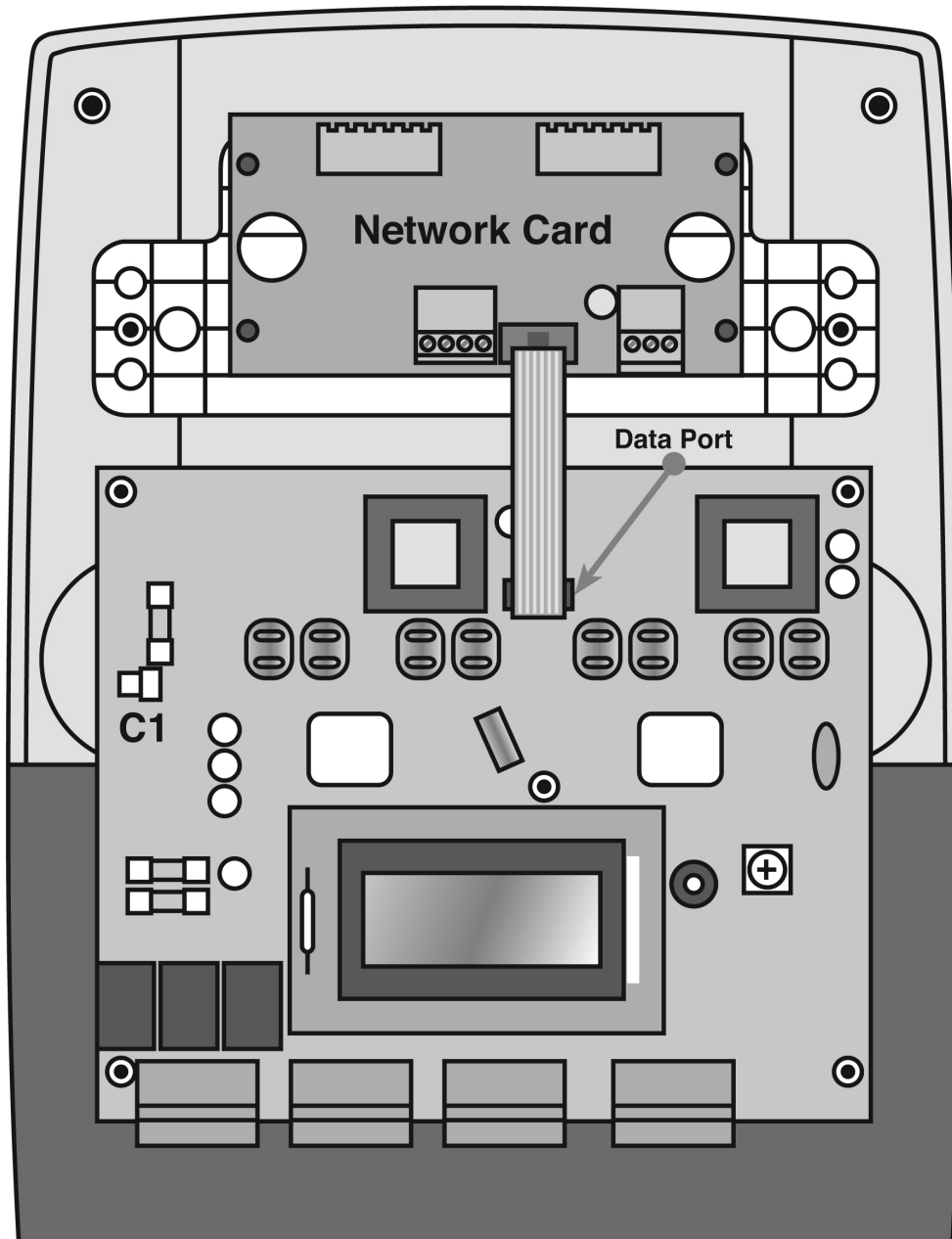

Large network

Up to 32 Druid LCD 2x energisers (64 Zones) can be networked together.

Each of the energisers will need to have a unique address in the range **1-32**.

The energiser's large network address is set using installer code **51??*#** detailed on **page 27** of this manual.

Often when networking energizers it is possible to come into contact with more than one energized fence at a time. In this case, for safety, the energizers should be synchronised with one another. Synchronisation is achieved by either making all energizers dependant on the timing of one of the energizers in the network, or by making all energizers dependant on an accurate external clock source with a period of one second, such as the GPS receiver available from Nemtek.

Use the installer code **503?*#**, detailed on **page 26** of this manual, to change the synchronisation behaviour of an energizer. Synchronisation may also be an issue in non-networked fences that are adjacent at some point.

Detailed information on networking is provided in Network Guide for Druid LCD 2x Energizers available on the Nemtek website.

Detailed service indicators & fuses

When the energizer front cover is opened while displaying a service condition (spanner symbol), if the service condition is still present, further information will be displayed indicating the cause of the service condition as listed below.

- A** = Aux fuse blown
- I** = Fence interference detected
- S** = High voltage boost circuit failure, SCR failure or rapid triggering
- B** = Battery fuse blown, battery fault or not connected
- N** = Slave energizer communication failure
- V** = Output high voltage sense error
- F** = High voltage boost circuit control loss

FUSE DESCRIPTION AND FAULT SYMPTOMS

All fuses are of the "fast blow" type with a 2A rating. Main fuse 4A

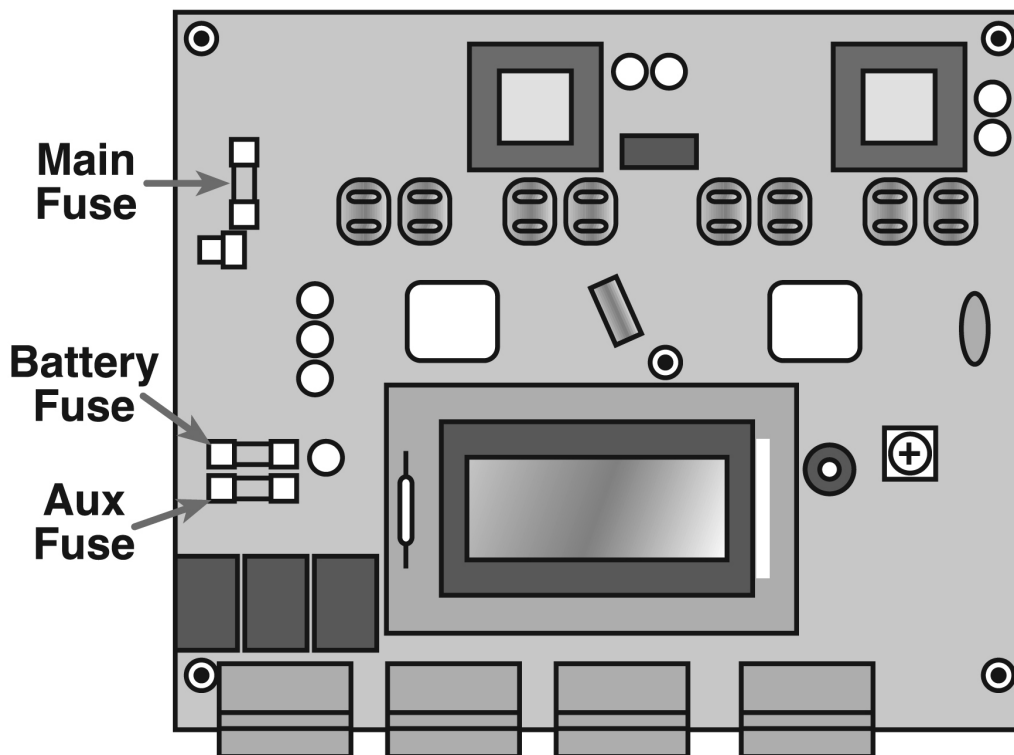

Main Fuse: Energizer displays a battery symbol, and not the mains power symbol (plug).

Battery Fuse: Energizer does not operate when mains power is disconnected.

Aux Fuse: The Siren and strobes do not function.

Installation notes

- Keep the wires to the fence separate from the keypad, gate, siren, strobe and mains wiring.
- Do not try and modify the energizer. Any unauthorized modifications will null and void the warranty and possibly render the unit illegal.
- If the external On/Off facility is used, the wire between the remote switch and the energizer can be up to a 100m in length. The switch contact must be open for the fence to be energized.
- A remote receiver can obtain 12VDC from the keypad bus. Current consumption must not exceed 0.1 Amps. This is not sufficient to supply power for an armed response transmitter.
- The siren and strobe lights together must not draw more than 1.8Amps.
- Never use the energizer battery to power a radio alarm transmitter or alarm panel.
- The wire between the magnetic gate switch and the energizer can be up to a 100m in length, but must not run parallel with any fence wires. The gate switch must be open circuit if the gate is open.
- The remote keypad cable must not exceed 100m in total length. Avoid running this cable parallel with any fence (high voltage) wires.
- You may connect a total of two keypads, one expansion card and one slave energizer to an energizer set to master.
- Use HT (high voltage) wire between the fence and energizer, including the earth wire. Never run these wires in the same conduit or through the same hole as the low voltage wiring.
- Always use ferrules or line clamps to connect two high voltage wires together. Avoid using dissimilar materials for connections like copper on steel.
- The fence must be earthed properly with three earth electrodes close to the energizer. The distance between the fence earth electrode and any other earth systems shall be not less than 2m for a security fence installation. (Typically, a suburban property installation), and 10m for an agricultural fence installation. (Typically a rural property installation.)
- When replacing the front of the energizer, hook the top in first while holding it an angle and then push it closed at the bottom. Fasten the lid down with the two cap screws.
- Always test the fence after installation for correct short and open-circuit alarming at various points along the fence.
- Do not use the energizer with non-rechargeable batteries.
- The energizer contains a sealed lead-acid battery that will vent to the atmosphere under certain conditions. For this reason, it is imperative that the energizer be installed in a well-ventilated area.
- Refer to the applicable laws concerning the installation of electric fences in your area.

Programmable options

RESTORE FACTORY DEFAULTS 2 3 8 9

Returns the energizer configuration, including all PINs to their factory default values

Enter this code within 60s of powering the energizer on after complete power removal, i.e mains and battery power removal simultaneously.

ENTER PROGRAMMING MODE * 0

Enables programming mode

Programmable options can only be changed once the energizer is placed into programming mode. The keypad will beep three times if the code is accepted. The factory default installer PIN is **012345**. Programming mode will timeout and exit after five minutes or upon entering the *# exit code.

CHANGE INSTALLER PIN 0 0 ^{NEW} *

Changes the factory default six-digit installer PIN to a new six-digit PIN

SIREN ON TIME 0 1 *

Sets the siren on (active) time

m = minutes, s = x10 seconds

Programmable range is **0101*#** (10s) to **0141*#** (4m:10s)

Factory default value is **0120*#** (2m:0s)

Siren active time is the amount of time that the siren will sound before automatically turning off, if not reset by the user.

SIREN OFF TIME 0 2 *

Sets the siren off (inactive) time

m = minutes, s = x10 seconds

Programmable range is **0201*#** (10s) to **0241*#** (4min:10s)

Factory default value is **0230*#** (3min:0s)

Siren off time is the amount of time that the siren will be forced to remain off after having automatically timed out (siren on time) from a previous alarm condition.

Programmable options

EVENTS BEFORE RE-ARM TIMEOUT **0 3 0 ? * #**

Sets the total unacknowledged events before the re-arm time comes into play

? = total events before re-arm time

Programmable range is **0301*#** (1 event) to **0307*#** (7 events)

Factory default value is **0303*#** (3 events)

See SIREN RE-ARM TIME below.

SIREN RE-ARM TIME **0 4 d h h m m * #**

Sets the sirens re-arm time period

d = day, hh = x10 hours + hours, mm = x10 minutes + minutes

Programmable range is **0400001*#** (1min) to **0471402*#** (7d:14h:02min)

Factory default value is **0410000*#** (1d:00h:00min)

The re-arm time comes into play after the siren has sounded for the set number of events without being manually reset by the user. This is required by law to prevent an alarm from sounding indefinitely while the owner is not home to correct the alarm condition.

RELAYS ACTIVE OPEN **0 0 6 ? * #**

Set the active state of all three relays on the energizer PCB.

? = 0 (relay closed when active) or 1 (relay open when active)

Factory default value is **0060*#** (relay normally open, closed on activation)

Typically used when the energizer is connected to an alarm system requiring a normally closed input.

STROBE LIGHT Z1 RELAY FUNCTION **0 0 1 ? * #**

Selects between zone 1 strobe light only, zone 1 & 2 combined strobe light or zone 1 on/off.

? = 0 (zone 1 strobe light), 1 (zone 1 & 2 combined) or 2 (zone 1 on/off indication)

Factory default value is **0010*#** (zone 1 strobe light only)

The Z1 strobe light relay can be assigned to be active when an alarm is triggered on zone 1 only (0), if an alarm is triggered on either zone 1 or zone 2 (1), or if zone 1 is energized (2).

Programmable options

STROBE LIGHT Z2 RELAY FUNCTION **0 0 2 ? * #**

Selects between zone 2 strobe light, zone 1 & 2 on/off or zone 2 on/off.

? = 0 (zone 2 strobe light), 1 (zone 1 & 2 on/off) or 2 (zone 2 on/off)

Factory default value is **0020*#** (zone 2 strobe light only)

The Z2 strobe light relay can be assigned to be active when an alarm is triggered on zone 2 only (0), if zone 1 & 2 are energized (1) (both zone 1 and zone 2 need to be energized for the relay to be active), or if zone 2 is energized (2).

SIREN RELAY FUNCTION **0 0 3 ? * #**

Selects between gate alarm, energizer on/off indication, or service alarm, when in ALARM SENSOR MODE only.

? = 0 (gate alarm) or 1 (energizer on/off indication), or 2 (service alarm)

Factory default value is **0030*#** (gate alarm)

The siren relay can be assigned to be active when a gate alarm occurs (0), or to indicate when the fence is energized (1), or to activate on service alarm (2). *Note that both zone 1 and zone 2 need to be active for the relay to indicate the fence is energized.

ALARM SENSOR MODE **4 0 8 ? * #**

Enable or disable the energizer alarm sensor mode.

When this mode is active, the display will indicate "AlmSensr"

? = 0 (conventional energizer mode) or 1 (alarm sensor mode)

Factory default value is **4080*#** (conventional energizer mode)

When in alarm sensor mode, the strobe relays, regardless of STROBE LIGHT Z1/Z2 RELAY FUNCTION settings, will function as follows;

The Zone 1 strobe relay is active only as long as zone 1 is in alarm condition.

The Zone 2 strobe relay is active only as long as zone 2 is in alarm condition.

The siren relay by factory default will be active only as long as the gate is in alarm condition. If however the siren relay function has been altered using the SIREN RELAY FUNCTION, the siren relay will be active as long as both fence zone 1 and zone 2 are energized.

Additional status information can be obtained, such as, zone active, zone low voltage mode, zone check condition, mains fail, service and tamper conditions, by fitting an expansion card onto the keypad bus.

This mode is typically used when the energizer is connected to an alarm system and no user interaction with the energizer will take place. The energizer is thus treated as simply another alarm detecting sensor for the alarm panel.

Programmable options

GATE ALARM DELAY TIME

1 0 m s * #

Sets the gate alarm delay time

m = minutes, s = x10 seconds

Programmable range is **1001*#** (10s) to **1041*#** (4min:10s)

Factory default value is **1010*#** (1min:0s)

The gate alarm will only sound once the gate has remained open for longer than the GATE ALARM DELAY time. The GATE ALARM INSTANT user code can be used to temporarily override this delay period, and the GATE ALARM BYPASS user code can be used to temporarily disable the gate alarm function.

GATE CHIME ON CLOSE

1 1 9 ? * #

Enable or disable a gate close chime, only when gate chiming is enabled.

? = 0 (no chime on close) or 1 (chime on close)

Factory default value is **1190*#** (no chime on close)

The user can enable a gate chime notification using the GATE CHIME user code, as detailed in the Druid LCD User Manual. This GATE CHIME ON CLOSE installer code additionally enables chiming on closure of the gate as well.

INPUT TOGGLE SELECT

1 1 1 ? * #

Selects toggling or direct on/off control of the fence.

? = 0 (direct control) or 1 (toggle control)

Factory default value is **1110*#** (direct control)

With direct control, the fence is energized when the input transitions to open circuit. With toggle control, the fence operating state is toggled each time the input transitions from closed to open circuit.

FENCE CONDITION CHECK LEVEL

2 0 1 ? * #

Sets the value at which the CHECK message will be displayed should the fence condition indicator reduce to or below this set value.

? = check level between 3 and 6

Programmable range is **2013*#** (3 = fair to poor) to **2016*#** (6 = good)

Factory default value is **2014*#** (4 = fair)

*Can be directed to a specific zone, using KEYPAD ZONE FOCUS.

Programmable options

FENCE STATE AT POWER ON

2 0 2 ? * #

Sets the operating state that the fence is returned to after a complete power failure has ended.

? = 0 (off), 1 (on) or 2 (fence returns to on/off state at power loss)

Factory default value is **2022*#** (fence returns to on/off state at power loss)

A complete power failure occurs when the energizer shuts down due to the internal battery running flat during a prolonged mains power failure.

*Can be directed to a specific zone, using KEYPAD ZONE FOCUS.

FENCE INTERFERENCE ALARM

2 0 3 ? * #

Enables or disables the fence interference detected alarm function.

? = 0 (disabled), 1 (enabled)

Factory default value is **2031*#** (enabled) for DRUID_18

Factory default value is **2030*#** (disabled) for DRUID_114

Fence interference may occur when a neighbouring fence comes into contact with the fence been driven by this energizer or when criminals attempt to defeat the energizer fence alarm detection mechanism.

*Can be directed to a specific zone, using KEYPAD ZONE FOCUS.

FENCE HIGH POWER VOLTAGE

2 1 k v * #

Sets the energizer output voltage during high power operation.

k = kilo volts, v = x100 volts

Programmable range is **2160*#** (6.0kV) to **2197*#** (9.7kV)

Factory default value is **2197*#** (9.7kV)

The fence condition indication value is affected by this value. Setting this value to a lower voltage will cause the fence condition indication to increase towards 9 (excellent) as the energizer works less hard to maintain the lower set voltage on the fence.

*Can be directed to a specific zone, using KEYPAD ZONE FOCUS.

Programmable options

FENCE HIGH POWER CHECK LEVEL **2 2 k v * #**

Sets the value at which the CHECK message will be displayed should the fence return voltage reduce to below this set value when operating in high power mode.

k = kilo volts, v = x100 volts

Programmable range is **2230*#** (3.0kV) to **2260*#** (6.0kV)

Factory default value is **2240*#** (4.0kV)

The check level must always be set above the alarm level for the new setting to be accepted.

*Can be directed to a specific zone, using KEYPAD ZONE FOCUS.

FENCE HIGH POWER ALARM LEVEL **2 3 k v * #**

Sets the value at which the BAD message will be displayed, and at which the alarm will sound should the fence return voltage reduce to or below this set value when operating in high power mode.

k = kilo volts, v = x100 volts

Programmable range is **2320*#** (2.0kV) to **2350*#** (5.0kV)

Factory default value is **2330*#** (3.0kV)

The alarm level must always be set below the check level for the new setting to be accepted.

*Can be directed to a specific zone, using KEYPAD ZONE FOCUS.

FENCE ALARM DELAY **2 5 ? ? * #**

Sets the number of violating fence pulses that have to occur before the alarm is activated.

?? = number of pulses before alarm occurs

Programmable range is **2501*#** (1 pulse) to **2515*#** (15 pulses)

Factory default value is **2503*#** (3 pulses) for DRUID_18

Factory default value is **2507*#** (5 pulses) for DRUID_114

*Can be directed to a specific zone, using KEYPAD ZONE FOCUS.

FENCE LOW POWER VOLTAGE **2 7 k v * #**

Sets the energizer output voltage during low power operation.

k = kilo volts, v = x100 volts

Programmable range is **2709*#** (0.9kV) to **2719*#** (1.9kV)

Factory default value is **2715*#** (1.5kV)

*Can be directed to a specific zone, using KEYPAD ZONE FOCUS.

Programmable options

FENCE LOW POWER ALARM LEVEL **2 8 k v * #**

Sets the value at which the BAD message will be displayed, and the alarm will sound should the fence return voltage reduce to or below this set value when operating in low power mode.

k = kilo volts, v = x100 volts

Programmable range is **2805*#** (0.5kV) to **2815*#** (1.5kV)

Factory default value is **2808*#** (0.8kV)

*Can be directed to a specific zone, using KEYPAD ZONE FOCUS.

FENCE CONTROL ALGORITHM **3 0 1 ? * #**

Sets the fence control algorithm.

? = 0 (conventional) or 1 (arc detection and avoidance)

Factory default value is **3011*#** (arc detection and avoidance)

Conventional control will output a maximum of 8kV onto the fence to reduce the risk of arcing across insulators. Setting the FENCE HIGH POWER VOLTAGE to a value greater than 8kV will not raise the output voltage beyond 8kV when using conventional control. For more information on arc detection and avoidance control, read the FOREWORD at the front of this manual.

*Can be directed to a specific zone, using KEYPAD ZONE FOCUS.

BUZZER MUTE **4 0 0 ? * #**

Enables or disables the buzzer mute on the local energiser and keypad during an alarm condition.

? = 0 (disabled – buzzer unmuted) or 1 (enabled – buzzer muted)

Factory default value is **4000*#** (disabled)

MAGNETIC SWITCH **4 0 1 ? * #**

Enables or disables the magnetic switch.

? = 0 (disabled) or 1 (enabled)

Factory default value is **4011*#** (enabled)

When using a keypad, disable the magnetic switch to increase the level of security offered.

Programmable options

TAMPER ALARM

4 0 3 ? * #

Enables or disables the tamper alarm function.

? = 0 (disabled) or 1 (enabled)

Factory default value is **4031*#** (enabled)

When enabled, the tamper alarm will sound if the energizer front is opened while the fence is energized. The tamper symbol t will always be shown on the display, regardless of whether tamper alarm is enabled or disabled.

SERVICE ALARM

4 0 4 ? * #

Enables or disables alarming during a service condition.

? = 0 (disabled) or 1 (enabled)

Factory default value is **4041*#** (enabled)

DISPLAY INSTALLER TEL NUMBER

4 0 5 ? * #

Enables or disables the display of the installers telephone number during service condition.

? = 0 (disabled) or 1 (enabled)

Factory default value is **4050*#** (disabled)

When enabling this function, don't forget to set a new telephone number using the (10-digit new telephone number) # code below.

SHOW KEY PRESSES ON LCD

4 0 6 ? * #

Enables or disables the displaying of keypad key presses on the energizer display.

? = 0 (disabled) or 1 (enabled)

Factory default value is **4061*#** (enabled)

For increased security when the energizer and keypad are far apart, it may be desirable to disable this function and so prevent the user PIN being read from the energizer display.

SOLAR POWERED INSTALLATION

4 0 7 ? * #

Modifies the energizer operation for permanent battery operation.

? = 0 (disabled, requires mains power) or 1 (solar installation)

Factory default value is **4070*#** (disabled)

If the energizer is to be run permanently from battery power, which is typically the case when running a solar powered site, then enabling this function will prevent the energizer from reacting to mains power loss as an error condition.

Programmable options

MAINS FAIL CHIME

4 0 9 ? * #

Enable or disable mains fail chime.

? = 0 (no chime on mains fail) or 1 (chime on mains fail)

Factory default value is **4091*#** (chime on mains fail)

The energizer and connected keypad will chime upon detecting mains failure, if enabled.

SLAVE ENERGIZER PRESENT

5 0 0 ? * #

Enable or disable whether a slave energizer should be present.

? = 0 (Master only 2 zone system) or 1 (Slave connected 4 zone system)

Factory default value is **5000*#** (Master only 2 zone installation)

The master energizer needs to be configured as to whether a slave energizer is connected, creating a four-zone system, or if it is a master only two zone system. This is required so that a communication failure (service alarm) can be generated should the slave energizer not respond to the master's request for information, and so that the keypad can be dealt with correctly as either a two or four zone installation.

Programmable options

EXPANSION CARD CONFIGURATION 5 0 2 ? *

Selects the configuration used in assigning a function to each of the ten relays and each of the four inputs on the expansion card.

? = configuration to select (contact NEMTEK for customized configurations)

Programmable range is **5020*#** to **5022*#**

Factory default value is **5020*#** (Configuration 0)

The expansion card address jumper must be set to 1 for the master energizer info or 2 for the slave.

Configuration 0.

Relay 1 = Expansion card communication timeout.	Relay 6 = Mains fail.
Relay 2 = Zone 1 On/Off status.	Relay 7 = Battery low or Service alarm.
Relay 3 = Zone 2 On/Off status.	Relay 8 = Zone 1 in "Check".
Relay 4 = Zone 1 in low voltage mode.	Relay 9 = Zone 2 in "Check".
Relay 5 = Zone 2 in low voltage mode.	Relay10 = Energizer tamper state.
Input 1 = Zone 1 On / Off control.	Input 3 = Zone 1 Low / High voltage select.
Input 2 = Zone 2 On / Off control.	Input 4 = Zone 2 Low / High voltage select.

Configuration 1.

Relay 1 = Expansion card communication timeout.	Relay 6 = Zone 1 in "Check".
Relay 2 = Zone 1 On/Off status.	Relay 7 = Zone 2 in "Check".
Relay 3 = Zone 2 On/Off status.	Relay 8 = Mains fail, battery low, service, tamper.
Relay 4 = Zone 1 in low voltage mode.	Relay 9 = Zone 1 in alarm.
Relay 5 = Zone 2 in low voltage mode.	Relay10 = Zone 2 in alarm.
Input 1 = Zone 1 On / Off control.	Input 3 = Zone 1 Low / High voltage select.
Input 2 = Zone 2 On / Off control.	Input 4 = Zone 2 Low / High voltage select.

Configuration 2.

Relay 1 = Expansion card communication timeout.	Relay 6 = Mains fail.
Relay 2 = Zone 1 On/Off status.	Relay 7 = Battery low, service alarm.
Relay 3 = Zone 2 On/Off status.	Relay 8 = Zone 1 high voltage alarm.
Relay 4 = Zone 1 in low voltage alarm.	Relay 9 = Zone 2 high voltage alarm.
Relay 5 = Zone 2 in low voltage alarm.	Relay10 = Tamper.
Input 1 = Zone 1 high voltage activate.	Input 3 = Zone 1 low voltage activate.
Input 2 = Zone 2 high voltage activate.	Input 4 = Zone 2 low voltage activate.

Programmable options

MASTER ENERGIZER PASSIVE SYNC 5 0 3 ? * #

Sets whether a master energizer should actively drive, or passively listen to the SYNC signal.

? = 0 (Master with active SYNC) or 1 (Master with passive SYNC)

Factory default value is **5030*#** (Master with active SYNC)

In a single energizer installation, the energizer provides its own timing pulse.

For a number of master energizers to all pulse together in a synchronized fashion, this code allows the switching of an energizer from active sync to passive sync.

In passive sync mode the energizer monitors the sync input for a sync pulse and sets its timing according to this sync pulse. The sync pulse can come from another master energizer set to active sync, via the keypad bus directly, or via a network, or the pulse could also be provided from a Nemtek GPS module. The GPS module extracts absolute time from the network of satellites making up the global position system (GPS).

The advantage of using a Nemtek GPS sync module is that any number of D24 energizers can be synchronized over vast distances without any physical network connections between the energizers.

To create a network of synchronized energizers using one of the energizers as the timing master, first enter this code into all energizers excepting one. You need to leave exactly one master energizer with an active SYNC, to which all passive SYNC masters will synchronize, once connected together.

To connect the energizers together, from the keypad/networking connector, wire the synchronize line (SYNC) of all energizers together, and wire the negative line (-) of all energizers together.

LARGE NETWORK TOPOLOGY 5 0 4 ? * #

Switches the large network topology from daisy chain to multi drop.

? = 0 (Daisy chain) or 1 (Multi drop)

Factory default value is **5040*#** (Daisy chain)

See the "D24 RS485 Network card" manual for further information on network topologies.

Programmable options

LARGE NETWORK ADDRESS

5 1 ? ? * #

Sets the address of an energizer connected in a large network.

Programmable range is **5101*#** (Address 1) to **5132*#** (Address 32)

Factory default value is **5100*#** (No address)

A maximum of 32 energizers can be networked together using network cards.

The factory default address of 0 is a broadcast address which allows an energizer to be found on a new network, but for the network to operate correctly the energizer must finally be assigned an address in the range of 1 to 32.

SET INSTALLER TEL NUMBER

**10 Digit Installer
Tel Number** _ _ _ _ _ #

Sets the telephone number to be displayed during a service condition.

The telephone number must be exactly 10 digits long and the displaying of this number must be enabled, as the factory default is to not display this number. (See code **4051*#**)

EXITING PROGRAMMING MODE

* #

Exits programming mode.

Basic definitions

- **Electric Fence:**
A barrier which includes one or more electric conductors, insulated from earth, to which electric pulses are applied by an energizer
- **Connecting Lead:**
An electric conductor, used to connect the energizer to the electric fence or the earth electrode
- **Electric Security Fence:**
A fence used for security purposes which comprises an electric fence and a physical barrier electrically isolated from the electric fence
- **Public Access Area:**
Any area where persons are protected from inadvertent contact with pulsed conductors by a physical barrier
- **Pulsed Conductors:**
Conductors which are subjected to high voltage pulses by the energizer
- **Secure Area:**
An area where a person is not separated from pulse conductors below 1,5m by a physical barrier

General requirements for electric security fences

Electric fences and their ancillary equipment shall be installed and operated and maintained in a manner that minimizes danger to persons, animals or environment, and reduces the risk of persons receiving an electric shock unless they attempt to penetrate the physical barrier, or are in the secure area without authority. Exposed conductive parts of the physical barrier shall be effectively earthed.

Electric fence constructions which are likely to lead to the entanglement of animals or persons shall be avoided, as entrapment can be lethal.

An electric fence shall not be supplied from two different energizers or from independent fence circuits of the same energizer.

For any two different electric fences, each supplied from a different energizer with independent timing, the distance between the wires of the two electric fences shall be at least 2.5m. If this gap is to be closed, this shall be affected by means of a physical barrier of high voltage electrically non-conductive material or an earthed conducting material such that the two separate electric security fences cannot be contacted at the same time.

Appendix

A spacing of 2.5 m shall be maintained between uninsulated connecting leads supplied from separate energizers. This spacing may be less where insulated cables are used or sleeving rated at 10kV.

Barbed wire or razor wire shall not be electrified by an energizer or placed physically close to an electric fence as these circumstances can create a lethal entanglement/entrapment hazard.

Any part of an electric fence which is installed along a public road or pathway shall be identified at frequent intervals by prominently placed warning signs securely fastened to the fence posts or firmly clamped to the fence wires. The size of the warning signs shall be at least 100mm x 200mm. The background colour of both sides of the warning plate shall be yellow. The inscription on the plate shall be in black.

The warning sign shall typically appear as depicted in the figure below or have the substance of "CAUTION: Electric fence". The inscription shall be indelible, inscribed on both sides of the warning plate and have a height of at least 25mm. The warning sign should be legible from the secure area and the public access area.

Each side of the electric security fence shall have at least one warning sign.

Warning signs shall be placed at;

- each gate
- each access point
- intervals not exceeding 10m
- adjacent to each sign relating to chemical hazards for the information of emergency services.



Gates in electric security fences shall be capable of being opened without the person receiving an electric shock.

Connecting leads that are run inside buildings shall be effectively insulated from the earthed structural parts of the building. This may be achieved by using insulated high voltage cable.

Connecting leads that are run underground shall be run in a conduit of insulating material or else insulated high voltage cable shall be used. Care shall be taken to avoid damage to the connecting leads due to external factors.

Connecting leads shall not be installed in the same conduit as the mains supply wiring, communication cables or data cables.

Connecting leads and electric fence wires shall not cross above overhead power or communication lines.

Mains supply wiring shall not be installed in the same conduit as signalling leads associated with the electric security fence installation.

Where an electric security fence passes below bare power line conductors, the highest metallic element shall be effectively earthed for a distance of not less than 5m on either side of the crossing point.

Crossings with overhead power lines shall be avoided wherever possible. If such a crossing cannot be avoided, it shall be made underneath the power line and as nearly as possible at right angles to it.

If connecting leads and electric fence wires are installed near an overhead power line, the clearances shall not be less than those shown in the table below.

<u>Power Line Voltage</u>	<u>Clearance</u>
Equal or less than 1kV	3 meter
Greater than 1kV, but equal or less than 33kV	4 meter
Greater than 33kV	8 meter

If connecting leads and electric fence wires are installed near an overhead power line, their height above the ground shall not exceed 3m.

This height applies either side of the orthogonal projection of the outermost conductors of the power line on the ground surface, for a distance of

- 2m for power lines operating at a nominal voltage not exceeding 1kV
- 15m for power lines operating at a nominal voltage exceeding 1kV

Ensure that all ancillary equipment connected to the electric security fence circuit provides a degree of isolation between the fence circuit and the supply mains equivalent to that provided by the energizer. Protection from the weather shall be provided for the ancillary equipment unless this equipment is certified by the manufacturer as being suitable for use outdoors, and is of a type with a minimum degree of protection IPX4.

Programmable options summary

RESTORE FACTORY DEFAULTS	2 3 8 9 #
ENTER PROGRAMMING MODE	(6 digit installer PIN) * 0 #
CHANGE INSTALLER PIN	0 0 (new 6 digit installer PIN) #
SIREN ON TIME	0 1 m s * #
SIREN OFF TIME	0 2 m s * #
EVENTS BEFORE RE-ARM TIMEOUT	0 3 0 ? * #
SIREN RE-ARM TIME	0 4 d h h m m * #
RELAY ACTIVE OPEN	0 0 6 ? * #
STROBE LIGHT Z1 RELAY FUNCTION	0 0 1 ? * #
STROBE LIGHT Z2 RELAY FUNCTION	0 0 2 ? * #
SIREN RELAY FUNCTION	0 0 3 ? * #
GATE ALARM DELAY TIME	1 0 m s * #
GATE CHIME ON CLOSE	1 1 9 ? * #
INPUT TOGGLE SELECT	1 1 1 ? * #
FENCE CONDITION CHECK LEVEL	2 0 1 ? * #
FENCE STATE AT POWER ON	2 0 2 ? * #
FENCE INTERFERENCE ALARM	2 0 3 ? * #
FENCE HIGH POWER VOLTAGE	2 1 k v * #
FENCE HIGH POWER CHECK LEVEL	2 2 k v * #
FENCE HIGH POWER ALARM LEVEL	2 3 k v * #
FENCE ALARM DELAY	2 5 m s * #
FENCE LOW POWER VOLTAGE	2 7 k v * #
FENCE LOW POWER ALARM LEVEL	2 8 k v * #
FENCE CONTROL ALGORITHM	3 0 1 ? * #
BUZZER MUTE	4 0 0 ? * #
MAGNETIC SWITCH	4 0 1 ? * #
TAMPER ALARM	4 0 3 ? * #
SERVICE ALARM	4 0 4 ? * #
DISPLAY INSTALLER TEL NUMBER	4 0 5 ? * #
SHOW KEY PRESSES ON LCD	4 0 6 ? * #
SOLAR POWERED INSTALLATION	4 0 7 ? * #
ALARM SENSOR MODE	4 0 8 ? * #
MAINS FAIL CHIME	4 0 9 ? * #
SLAVE ENERGIZER PRESENT	5 0 0 ? * #
EXPANSION CARD MAPPING	5 0 2 ? * #
MASTER ENERGIZER PASSIVE SYNC	5 0 3 ? * #
LARGE NETWORK TOPOLOGY	5 0 4 ? * #
LARGE NETWORK ADDRESS	5 1 ? ? * #
SET INSTALLER TEL NUMBER	(10 digit installer tel number) #
EXITING PROGRAMMING MODE	* #

IEC Safety Information

- There are no user serviceable parts inside the energizer.
- If the supply cord is damaged, it must be replaced by the manufacturer, its service agent, or similar qualified persons in order to avoid a hazard.
- This appliance is not intended for use by persons (including children) with reduced physical, sensory or mental capabilities, or lack of experience and knowledge, unless they have been given supervision or instruction concerning use of the appliance by a person responsible for their safety.
- Electric fencing can be lethal. Avoid head contact with the fence. Ask the installer to explain the options of current limiting resistors, the programmable output energy levels as well as the low-voltage operation of the energizer.

Rev 1.0, 1 May 2012

First release

Rev 1.1, 11 June 2012

Added more expansion card configurations

Rev 1.2, 25 Sep 2013

Added codes 51??*# and 504?*#

Rev 1.3, 12 Aug 2015

Updated illustrations, added D25/28 codes, added IEC Safety Information

Rev 1.4b, 20 June 2016

Corrected illustration on Pg9 and, typo on Pg19

Rev 1.5, 9 Nov 2017

Added codes 400?*#, 0012*# and 0022*#

Rev 1.6, 15 July 2020

Updated for D25 and D28 time synchronization